

FW, FWS, FWD

Series Pumps

1450 RPM

1750 RPM

3400 RPM

- Reversible Crankcase for Easy Right or Left Hand Mounting
- Hardened Stainless Steel Piston Guides
- Highly Efficient Stainless Steel Check Valves
- Solid Ceramic Plungers
- High & Low Pressure Seals: High Quality Buna-Textile Packings. Additional Anti-Extrusion Ring under the Seal

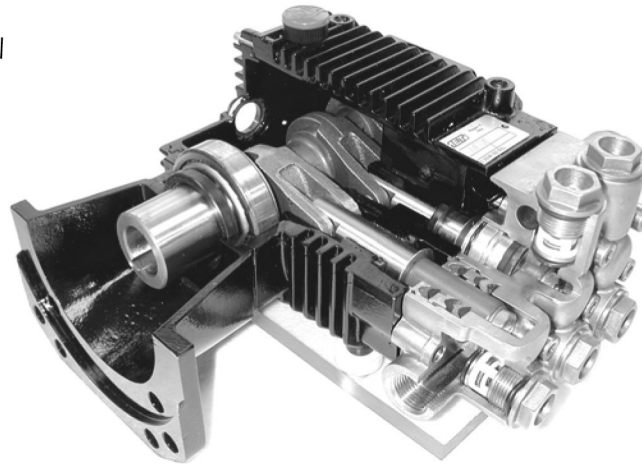

- Solid or Hollow Shaft
- Solid Brass Manifolds
- Special Forged Brass Oversized Connecting Rods
- Flange for Direct Mounting to Gas Engines or Electric Motors (Hollow shaft models only.)
- Die-Cast, Anodized Aluminum Crankcase
- High Quality Tapered Roller Bearings
- Optimal Oil Bath for High Speed Operation



FW

Series Pumps

1450 RPM - 24mm Solid Shaft



- 1/2" FPT inlet, 3/8" FPT discharge
- Anodized, die-cast aluminum crankcase
- Solid Ceramic Plungers
- Stainless steel check valves and piston guides
- Oversized bronze connecting rods
- Buna-textile V-packings
- Reversible crankcase for right or left hand mounting
- 24mm solid, keyed shaft

MODEL #	GPM	PSI	RPM	SHAFT	PISTON	WT.
FW 3530 S	3.5	3000	1450	24mm Solid	18mm	19.4
FW 4030 S	4.0	3000	1450	24mm Solid	18mm	19.4
FW 5030 S	5.0	3000	1450	24mm Solid	20mm	19.4
FW 5530 S	5.5	3000	1450	24mm Solid	20mm	19.4